



ROLLER AND COMPONENTS FOR MATERIAL HANDLING

*The Conveyor Idler For Future*

## Company Overview

**PT. Wahana Karya Sukses** is a company specialized in the production of heavy duty conveyor roller according to the application and benefits of various companies, such as : mining, cement, pulp and paper, power plant, fertilizer, etc. Our products brand is GEROLL.

Our workshop located in area of 17.000 square meter in Paku Haji, Tangerang. Having adequate space enable us to do manufacture in one roof. In order to meet your specification and requirements of rollers, we are equipped with automatic machines like pipe cutting machine, turning machine, two head automatic machine, press bearing machine and double head flat milling machine.

We are very concern on Quality and details work process to finishing, and we warranty every roller that manufactured in our workshop. Our mission is to dedicate ourselves to improve the lifetime of the rollers with full efficiency. With our highly experienced team and complete set facilities we are ready to serve your company by delivering best outcome to your needs of rollers and conveyor products.



# Manufacture Facilities

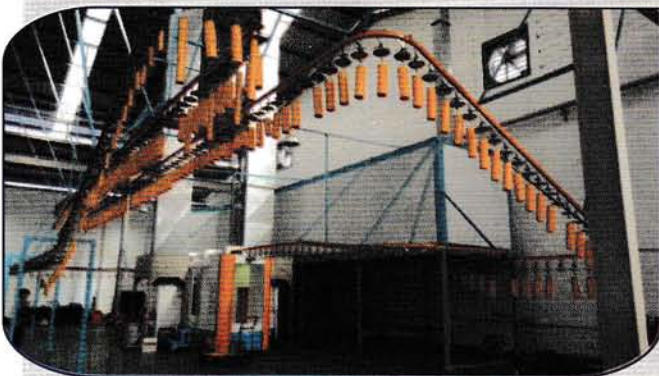

## Product Range

Gerolls offers a range of products for Conveyor and Material Handling application, such as :

### CONVEYOR ROLLER

- Carry Roller
- Impact Roller
- Return Roller
- Training Roller
- V-Return Roller
- Rubber Disc Return Roller

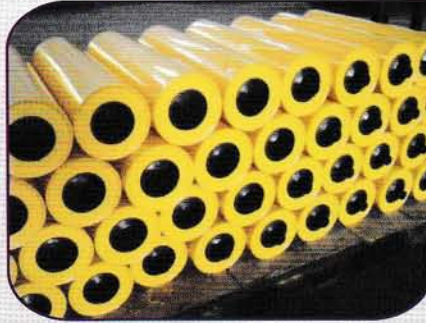

### BELT CLEANER

- Primary Belt Cleaner
- Secondary Belt Cleaner
- V-Plough



### BRACKET

- Carry Bracket
- Impact Bracket
- Flat Return Bracket
- Self Aligning Carry Bracket
- Self Aligning Return Bracket
- Retractable Bracket
- Transition Bracket



### PULLEY

- Drive Pulley
- Head Pulley
- Tail Pulley
- Snub Pulley
- Bend Pulley



## Roller

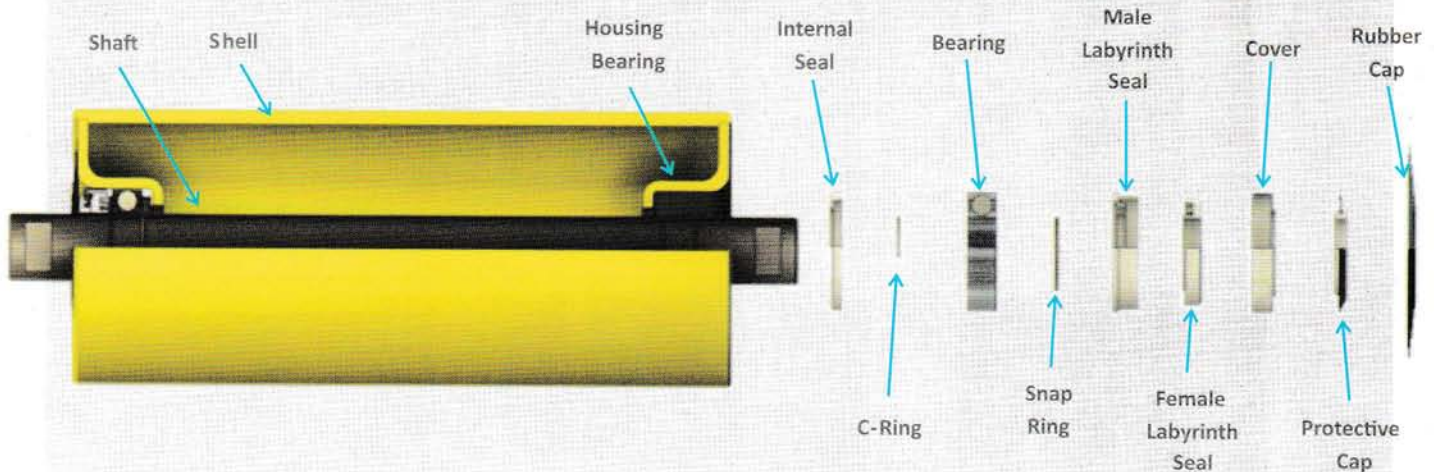

### Dynamic Balance

Our mass production assembly techniques guarantee a high degree of balance and minimum eccentricity. Impact forces during high speed operation is greatly reduced, thereby enhancing the life span of bearing.

### Welded End

The pipe and bearing housing are welded by an automatic circumferential welding machine. A welded construction will protect bearing by preventing the entry of dust and moisture at the clearance between the roller and bearing housing.

### Bearing and Housing Bearing

High quality deep groove ball bearing with C3 clearance are used in every Geroll roller. Bearing housings are formed in a multi stage pressing operation, providing such a high degree of accuracy for bearing and seal that no further machining is necessary.

### Seal

The bearing of Geroll roller are protected internally and externally by a protective sealing system which keep lubrication from leaking and prevent foreign matter from seeping into the roller. The components of the sealing system are :

- A protective and corrosion resistant shield mounted firmly on the roller shaft. This acts as a barrier against entry of foreign matter.
- A cover cap acting as dust trap for any particles that may eventually enter the roller.
- A labyrinth seal pre-loaded with grease which provides as a last line of defence before the bearing to keep out any dust particles that have penetrated to this stage.

### Inspection and Testing

All Geroll rollers are being tested to ensure their specifications conform to recommend standards.

### Maintenance Free Operation

The Multiple labyrinth seal type has built in non lubrication system which is maintenance free and hence reduce running cost.

# Roller Type

## CARRY

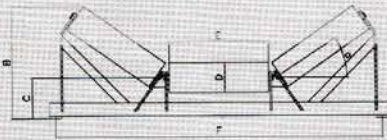

- Through Carry
- V - Carry
- Flat Carry

## IMPACT

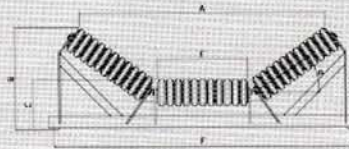

- Through Impact
- Flat Impact

## RETURN



- V- Return
- Flat Return
- Rubber Disc Return

## CARRY ROLLER FORM

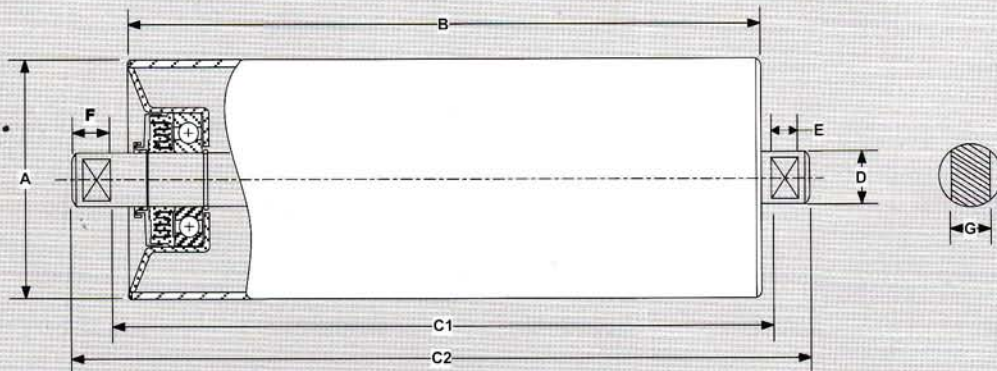

CONVEYOR	BELT WIDTH	A	B	C1	C2	D	E	F	G	SLOT TYPE	QTY	REMARK

Dimension in Milimeter

# Rollers

## IMPACT ROLLER FORM

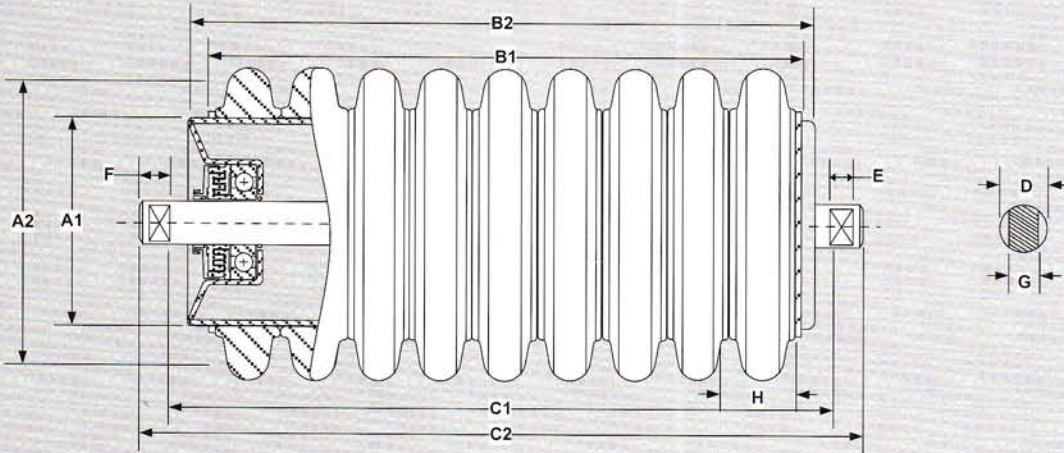

CONVEYOR	BELT WIDTH	A1	A2	B1	B2	C1	C2	D	E	F	G	H	n	SLOT TYPE	RUBBER TYPE	QTY

Dimension in Millimeter

## RETURN RUBBER ROLLER FORM

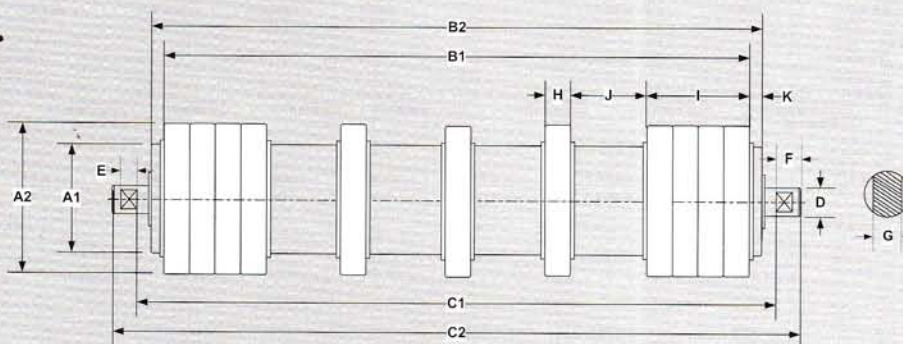

CONVEYOR	BELT WIDTH	A1	A2	B1	B2	C1	C2	D	E	F	G	H	I	J	K	n	SLOT TYPE	RUBBER TYPE	RUBBER CONFIG	QTY

Dimension in Millimeter

# Bracket Type

## BRACKET CARRY

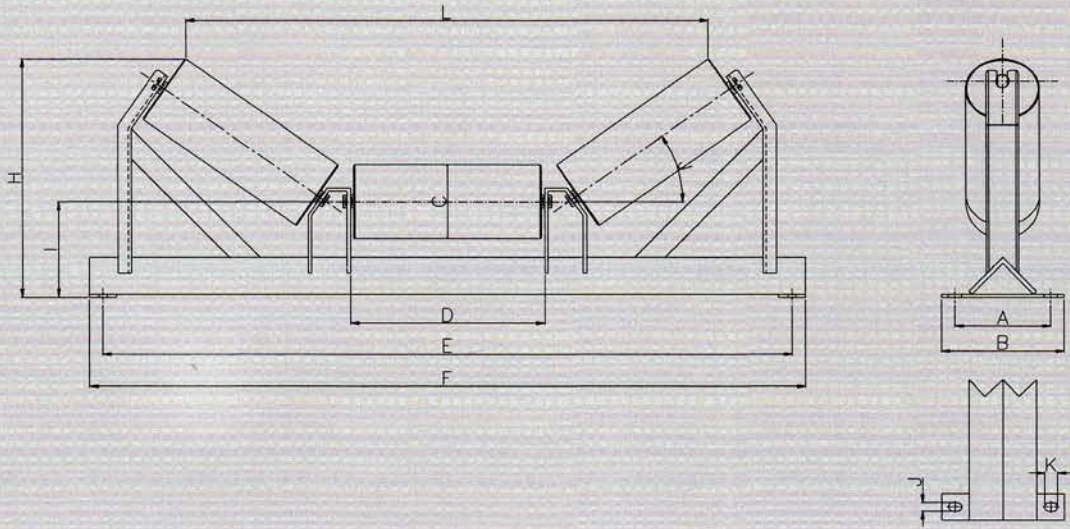

## BRACKET IMPACT

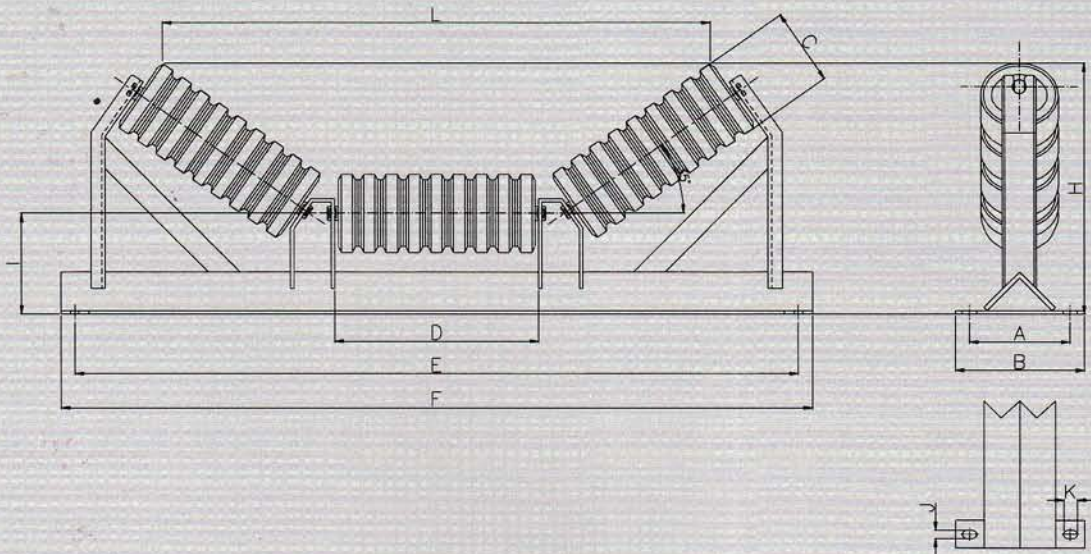

# Bracket Type

## BRACKET TRANSITION

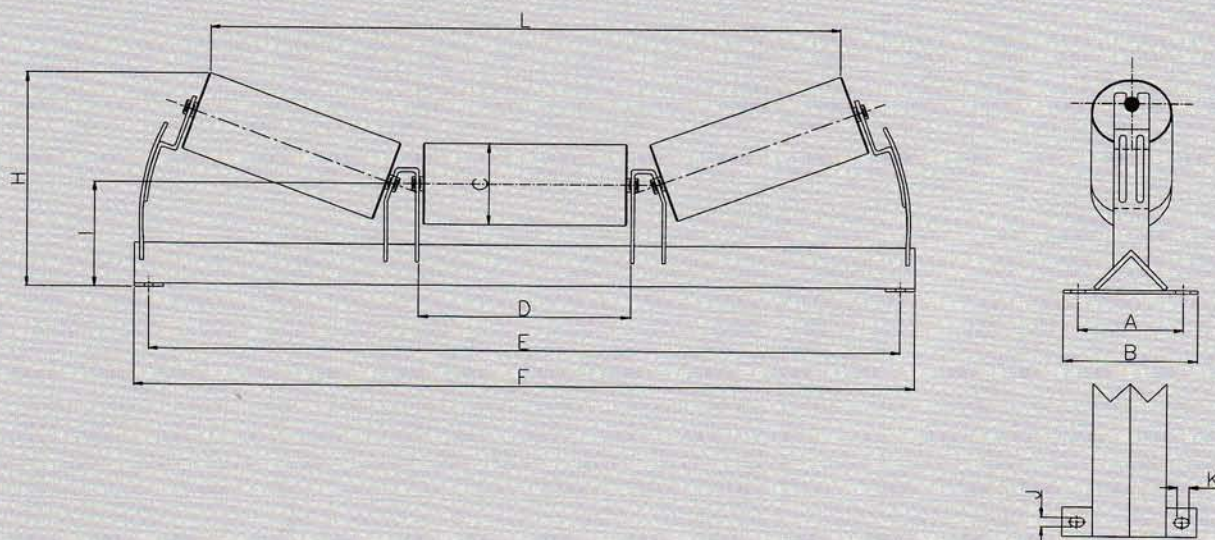

## BRACKET RETURN

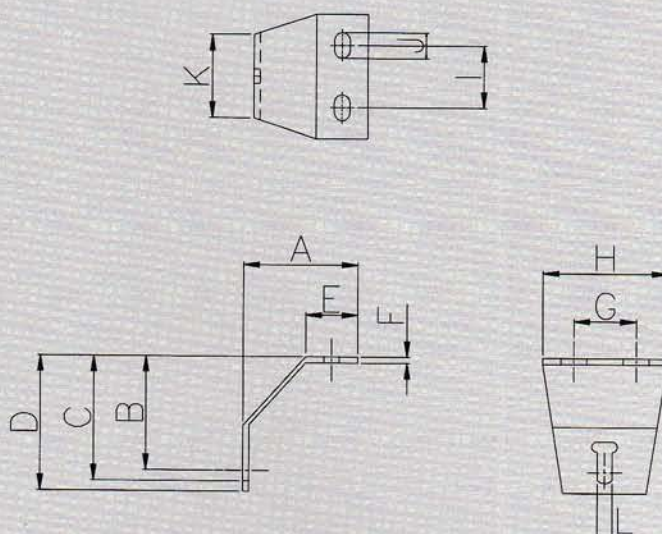

# Bracket Type

## BRACKET SACI

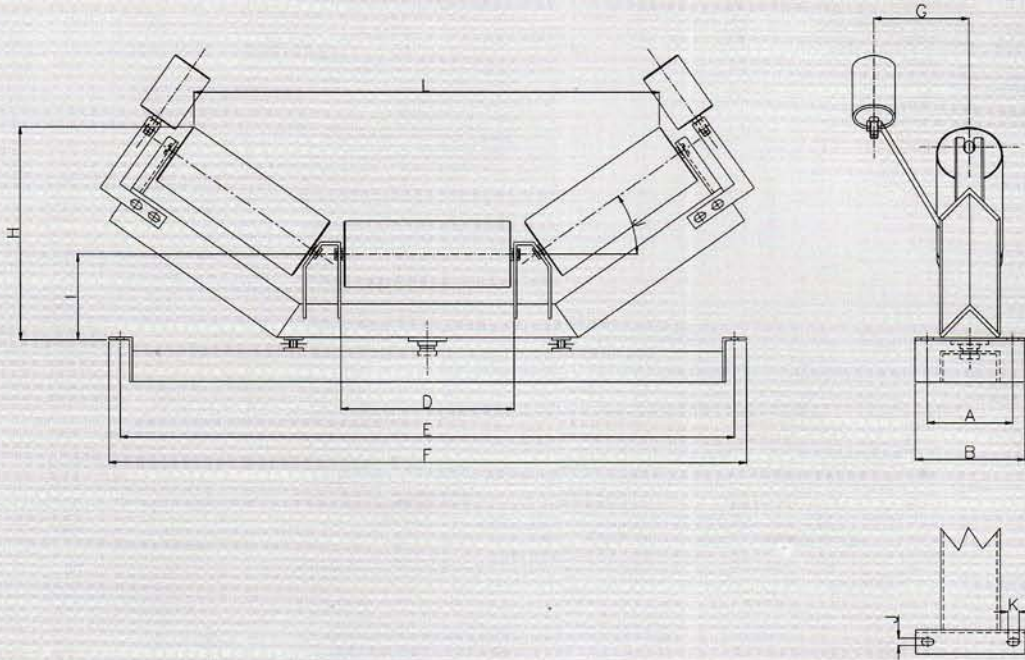

## BRACKET SARI

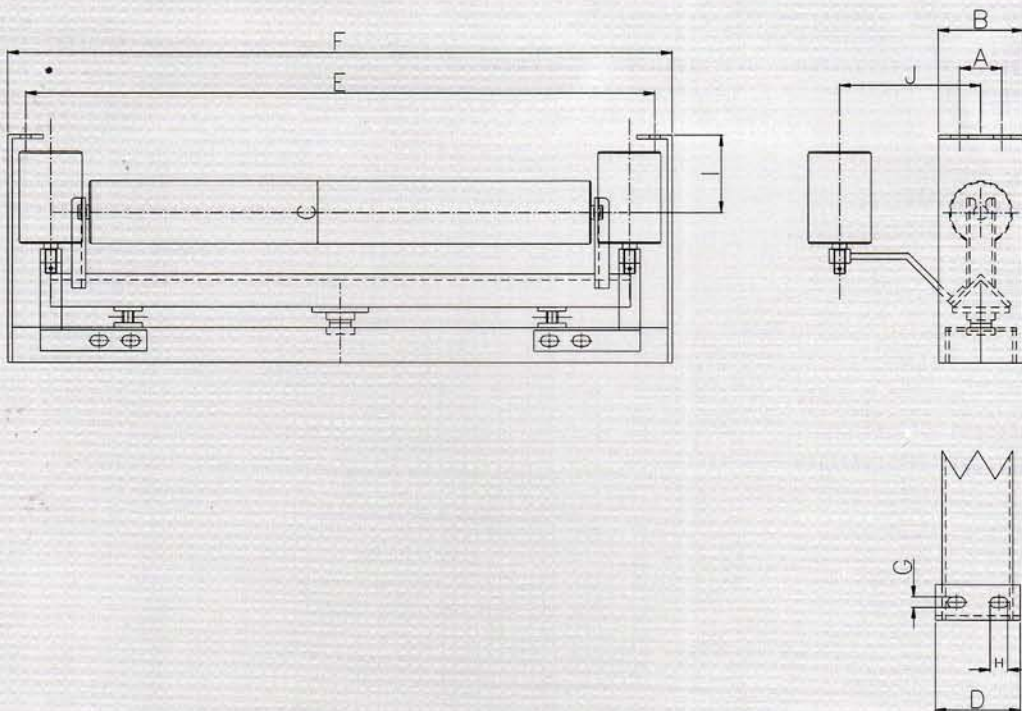

# Belt Cleaner

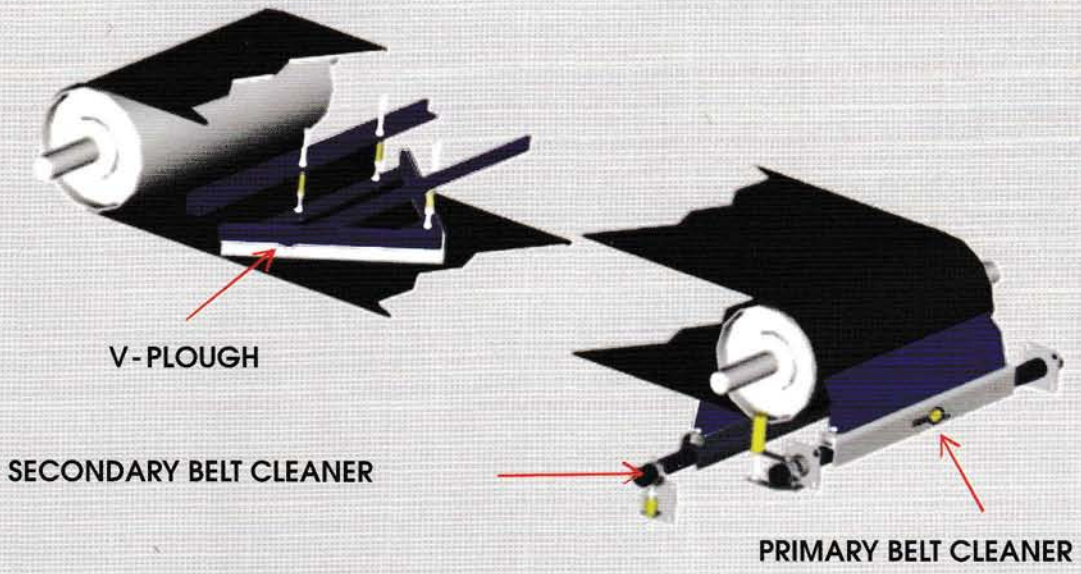

## PRIMARY BELT CLEANER

### Construction

- Segmented molded Polyurethane Blade
- Frame aluminum bar cast and Base frame from Pipe
- Adjustable spring tension turret for simple adjustable
- Blade tension, site gauge gives confirmation of optimal

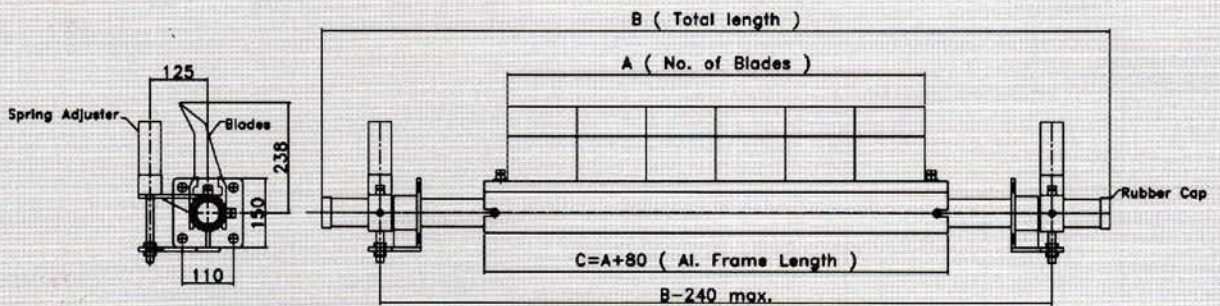
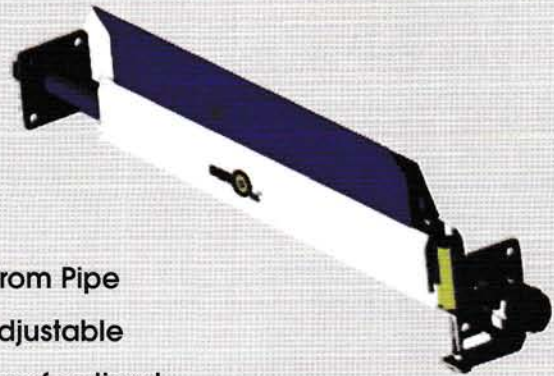

# Belt Cleaner

## SECONDARY BELT CLEANER

### Construction

- Extra heavy segmented molded urethane blade
- Heavy duty coil spring
- Extruded aluminum frame

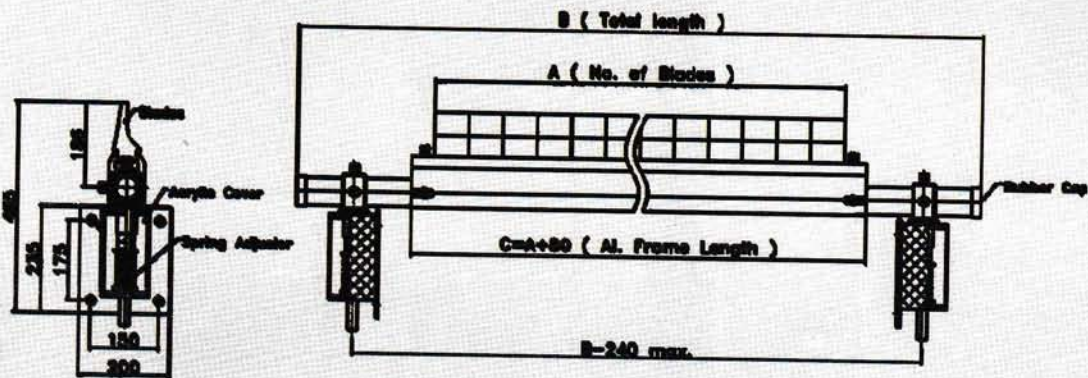

## V - PLOUGH

### Construction

- Standard carbon steel configuration
- Heavy duty construction with 1" thick urethane or rubber wiper blade for long and efficient cleaning

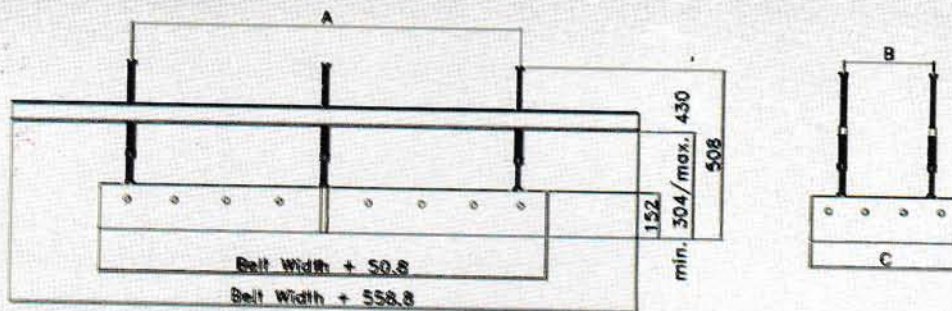
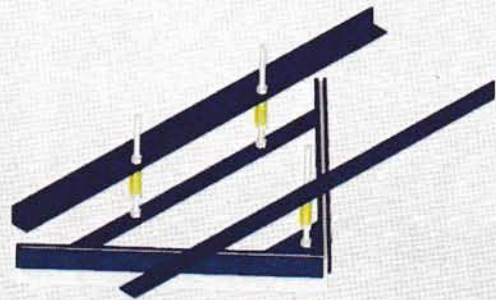

# Belt Cleaner

## MATERIAL SPECIFICATION

### POLY URETHANE BLADE

Material	Low Friction polyurethane
Temperature	Red : max.150 C, Blue : max.80 C
Tensile strength	285 kg / cm <sup>2</sup> ( ASTM D412 )
Laceration Resistance	115 kg / cm ( ASTM D624 )
Abrasion Resistance	35 mg ( ASTM D4060 ) TABER H-22 1000g 500 Rpm



### ALUMINIUM HOUSING

Material	Alumunium with glaze finish
Property	Finish Coating Anodizing



- Design with smooth edge to avoid contact when blades are worn out profile
- No screw / nut / metal fastener is required.

### SPRING TENSIONER

SPRING	<ul style="list-style-type: none"> <li>■ Provide required tension for blade to conveyor belt. enough to clean, not excessively to create friction / wear</li> <li>■ Low maintenance</li> </ul>
SPRING HOUSING	<ul style="list-style-type: none"> <li>■ Protector of spring</li> <li>■ Marked for tension adjustment</li> </ul>
ADJUSTER	<ul style="list-style-type: none"> <li>■ For proper tensioning</li> </ul>
PIPE CLAMP	<ul style="list-style-type: none"> <li>■ Ensure firm grip of pipe</li> </ul>

## Product Photos



Carry Roller



Impact Roller



Aligning Rubber Return Roller



Carry Bracket



Self Aligning Return Bracket

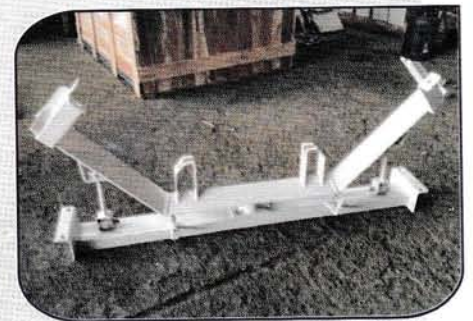

Self Aligning Carry Bracket



Primary Belt Cleaner



Secondary Belt Cleaner



Plough



Pulley



# Photos

